



AN EVOLUTION IN SITTING COMFORT.

MAXIMO

For medium- and heavy-duty tractors



New: the Maximo Evolution

- More comfort
- More performance



GRAMMER



A FULL LINEUP OF BENEFITS.



Maximum Suspension Comfort to Support Hard Work

The suspension system of the Maximo Evolution and the Maximo XXL is designed to absorb the vibrations and jolts typical of heavy tractors and tractors with axle and cabin suspension. It reduces the horizontal and vertical vibrations that arise when traveling at higher speeds, when working with rear attachments, or when working in rough terrain. This way, the driver keeps relaxed and comfortable - staying fit longer while keeping the vehicle fully under control at all times. This outstanding effect is achieved by a combination of low-frequency fore/aft and lateral suspension systems.



Sitting Comfort for Enhanced Well-Being

The other comfort features included in all Maximo models are not luxury items. Rather, they are essential for staying in good health, day after day. Take the ergonomic shape of the tapered backrests, for instance, or the wide cushions and armrests that maximize freedom of movement while preventing slipping and sliding. It's possible to flexibly adjust the backrest height, seat angle, seat length, and the lumbar support - so the Maximo can be easily customized to suit each driver's particular body and needs.

The Maximo Evolution also boasts active seat climate control. This system removes body moisture, so the driver always sits comfortably with a dry back and buttocks at a pleasant temperature. This is a great help for maintaining concentration on the job all day long.

Seat Adjustments Made Easy: "Design for Use"

The Maximo Evolution excels with its user-friendly "Design for Use". The controls are designed to let the user tell by touch how they work and which way to move them. Each has a unique shape to prevent them from getting mixed up. All controls are located where you would intuitively expect them. This makes it easy to position the seat for maximum comfort without having to read a manual first.



Adjustable Backrest Height

Every back is different. The integrated backrest extension provides for personalized comfort: precisely geared to the driver's body size to prevent poor posture from causing injuries and keep him relaxed during long stretches at the wheel. The setting range extends from 475 to 645 mm in 13 steps. If wished, the extension can be pushed all the way in.



Active Seat Climate System with Heating

The most important requirement for feeling good in the driver's seat is a pleasant temperature. But even with air-conditioning in the cabin, the driver sweats where his body contacts the seat. That is why Maximo Evolution is equipped with active seat climate control, which removes body moisture. This way the driver will never again sit at the wheel drenched in sweat. On cold days, the seat heating (standard feature) keeps you snug.

NEW

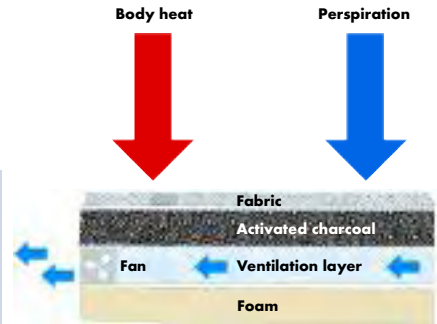

MAXIMUM SITTING COMFORT IS THE SUM OF MANY



Extra-Wide Cushions

These comfortable cushions prevent slipping and sliding.



Variable Seat Length

Adjustable in 5 steps to optimally support thighs of different lengths.

Flexible Seat Angle

Adjustable in 4 steps to reduce pressure on the backs of the knees.

210 mm Fore/Aft Adjustment

For easy positioning of the seat within the vehicle.

Fore/Aft Isolator

This feature minimizes vibrations when traveling fast, when pulling attachments or trailers, and when working in rough terrain.



Low-Frequency Suspension

This makes for especially comfortable sitting. Pneumatic low-frequency suspension with 12-volt compressor and suspension travel of up to 100 mm: an innovative solution that absorbs jolts and vibrations even more gently than before. This makes driving a calm, relaxed experience, especially at higher speeds. Besides the enhanced comfort, it also additionally protects the spine.

New Cover Design

Attractive and Robust.

Foldable Armrests with Fabric Covers

With adjustable height and angle. The cover effectively prevents the arms from rubbing and slipping.

DETAILS.



"Design for Use"

NEW

The Maximo Evolution is characterized by "Design for Use" - the controls are designed so the user can tell by touch how they work and which way to move them. Each has a unique shape to prevent them from getting mixed up. All controls are located where you would intuitively expect them.

Document Box

Tapered Backrest

For greater freedom of movement.

Pneumatic Lumbar Support

Back care at the press of a button. The pneumatic lumbar support adjusts quickly and precisely to the driver's back. A comfort feature that not only feels good but also prevents spinal injuries by ideally supporting the back.

Switch for Active Seat Climate System



MAXIMO EVOLUTION

Backrest with Adjustable Angle

Rotary Adapter

Pivots through 20° to facilitate getting in and out and checking equipment attached in back.



Lateral Suspension

No more sideways pitching! The lateral suspension feature noticeably eases the strains of everyday work. Vibrations and jolts perpendicular to the direction of travel are absorbed to protect the back.

80 mm Height Adjustment

The ideal seat position for every body size.

Adjustable Shock Absorber

For adjusting to different usage conditions.

Active Weight Adjustment

NEW Just sit down and go: the Maximo Evolution has sensors and an electronic control system that adjust the seat to the driver's weight completely automatically. This lets the seat's suspension system work optimally, providing for greater ergonomics and safety. Nothing needs to be done when changing drivers; the seat automatically adjusts to even the smallest variation in weight.

The model shown may deviate from the standard equipment.



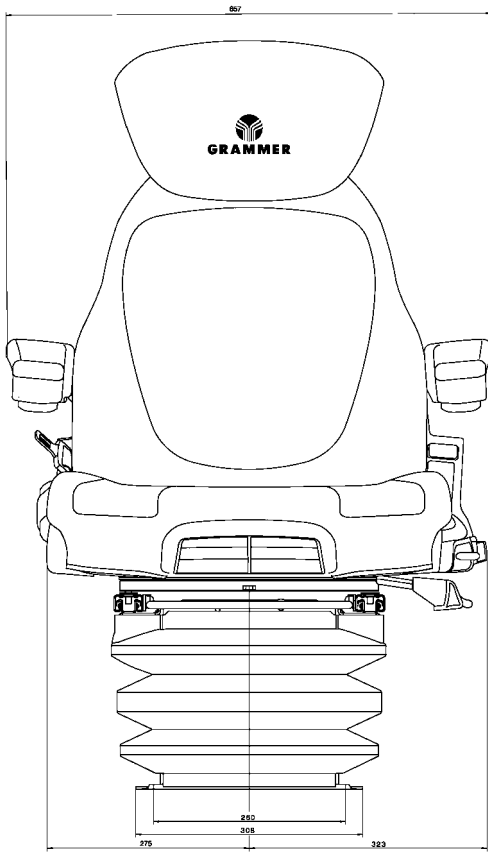

Seat cushion width: Maximo Evolution 550, Maximo XXL 550, Maximo XL 530, Maximo L 480

MAXIMO EVOLUTION

Maximo Evolution min. 337 - max. 412
 Maximo Evolution XL min. 312 - max. 387
 Maximo XL min. 263 - max. 342
 Maximo L min. 240 - max. 300

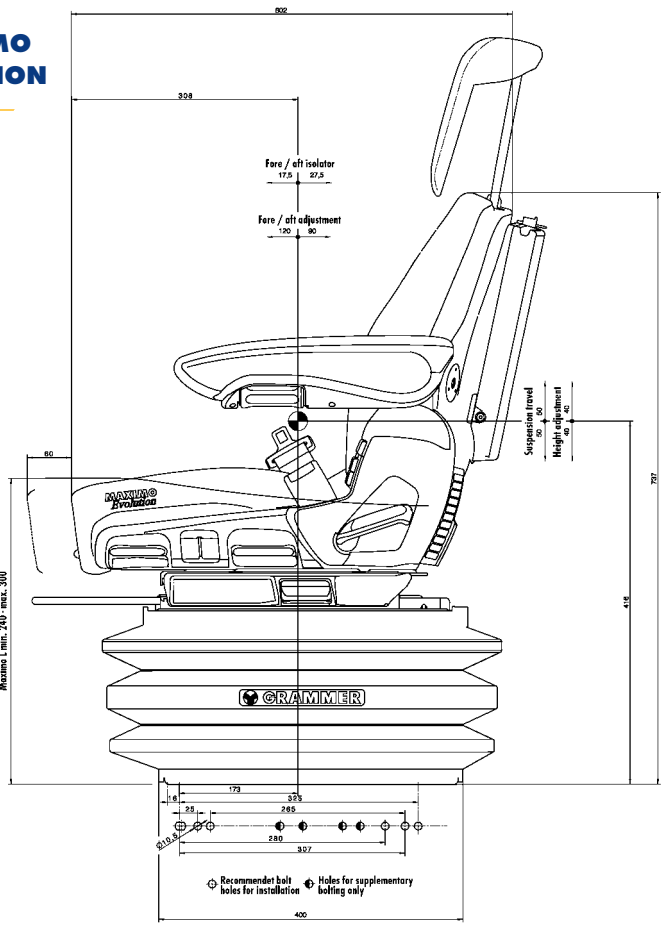

Air suspension

SITTING COMFORT BUILT TO MEASURE.

Mechanical

MAXIMO M

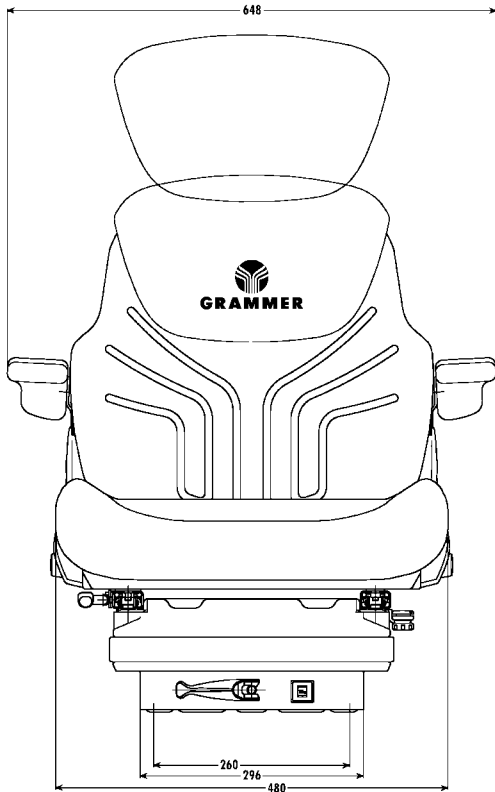

FRONT VIEW

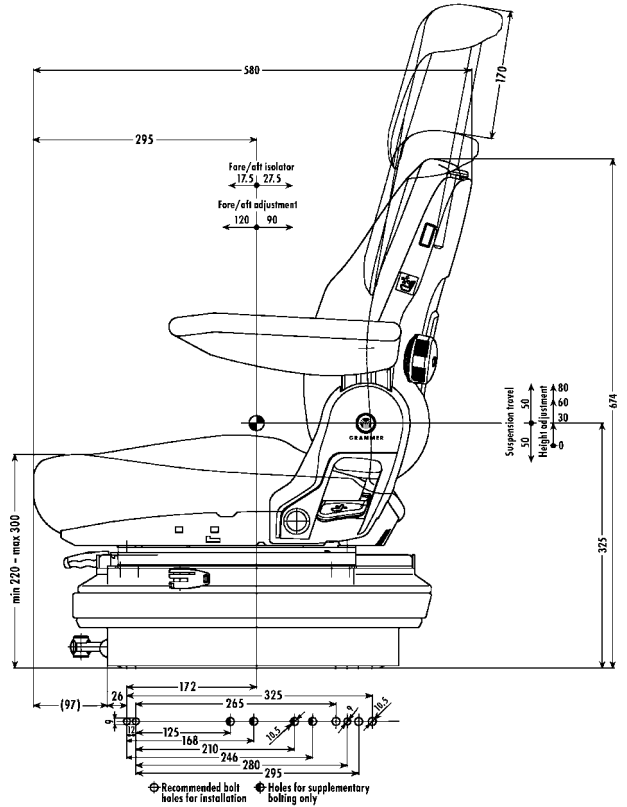

SIDE VIEW



MAXIMO EVOLUTION

The illustration may deviate from the standard-equipped model.

The MAXIMO Models Have a Lot in Common

Diversity is one of the Maximo's strengths. But every seat version includes the following basic features:
 Height-adjustable, folding armrests; 100 mm suspension travel; 210 mm fore/aft adjustment; backrest with adjustable angle; lumbar support; and fore/aft isolator. All seats can be supplied with lateral suspension, seat heating, a restraint system, and a seat switch (automatic driver detection for activating seat functions). The table shows all equipment options and available features at a glance.

MAXIMO FEATURES	MAXIMO EVOLUTION	MAXIMO XXL	MAXIMO XL	MAXIMO L	MAXIMO M
Article No. fabric	1081160	1027796	1027797	1027798	140487
Article No. imitation leather				1072515	
Document box	●	●	○	○	
APS (automatic positioning system)	●	●	●	●	
Armrests					
Height-adjustable and foldable	●	●	●	●	●
65 mm x 270 mm				●	●
60 mm x 380 mm, adjustable angle			●		
80 mm x 380 mm, adjustable angle		●			
80 mm x 380 mm, adjustable angle, with fabric cover	●				
Shock absorber					
Adjustment	●	●			
Non-adjustable			●	●	●
20° rotary adapter	●	●	●		
Suspension					
Air suspension with 12V compressor	●	●	●	●	
Mechanical suspension					●
Low-frequency suspension	●	●			
100 mm suspension travel	●	●	●	●	●
Weight adjustment	●	●	●	●	●
Automatic			●	●	
Active (electronic)	●				
Height adjustment					
60 mm, infinite (air-assisted)				●	
80 mm, infinite (air-assisted)	●	●	●		
60 mm, 3-step (mechanical)					●
Climate system					
Passive		●			
Active	●				
Fore/aft adjustment by up to 210 mm	●	●	●	●	●
Fore/aft isolator	●	●	●	●	●
Lumbar support					
Pneumatic	●	●			
Mechanical			●	●	●
Adjustable seatback angle	●	●	●	●	●
Integrated seatback extension	●	●	●	○	○
Lateral suspension	●	○	○	○	○
Seat cushion width	550 mm	550 mm	530 mm	480 mm	480 mm
Seat heating	●	○	○	○	○
Adjustable seat cushion length and angle	●	●	●		
Seat switch	●	○	○	○	○
OPTIONAL FEATURES					
Seatbelt	○	○	○	○	○

● Standard features ○ Options

Important information: Before using the seat the individual mounting situation (e.g. required holes) has to be checked.

**Seating systems that keep you fit:
GRAMMER offers state-of-the-art
products for all mobile work-
places - from tractors, construction
machines, and forklift trucks all
the way to trucks, buses, vans,
and trains. Ergonomically de-
signed, they set new standards
of sitting comfort and operating
convenience. Just ask us - we'll be
happy to personally advise you.**

