



HOME ON THE ROAD.

WHATEVER THE DISTANCE.

LINEA & TOUREA

High-Comfort Bus Driver Seating.



GRAMMER



SITTING PRETTY WITH A HEALTHY POSTURE.



Health on the Road.

A new design and state-of-the-art ergonomics, in attractive new-look cover fabrics. There's also a new name:

Linea for service buses and **Tourea for long-distance coaches**. Plus new comfort features that are not just luxuries, but an indispensable part of your day-to-day well being. The seats also come with infinite side support adjustment, pneumatic lumbar support, and a choice of left-hand or right-hand controls – to name just a few of the many features designed with driver health and safety in mind.

Fully Adjustable .

A Linea or Tourea seat gives bus drivers the active support they need for passive safety in the workplace: with just a few adjustments, it turns into a fully customized seat that precisely meets every driver's individual requirements. The innovative ergonomic basic shape and easy-to-use controls promote a healthy posture at all times. For municipal and service buses, there's also an optional swivel facility to make it easier for drivers to operate the till and leave the seat.

Relaxed Driver, Relaxing Trip.

Each and every time they sit behind the wheel, bus drivers bear a great deal of responsibility. They therefore need to be totally in control of the situation at all times, and able to deal effectively with all kinds of traffic situations. This calls for a driver seat that keeps the back as free as possible. With its attractively designed, unobtrusive three-point seatbelt system and integrated headrest as standard features, the Tourea provides maximum safety without restricting freedom of movement. After all, only a relaxed driver can give passengers a smooth, relaxed journey.

1 **Enhanced operating comfort**

Sophisticated and easy to use, in line with GRAMMER's operating philosophy.

- The most frequently used controls are within easy reach.
- All controls are located where you expect to find them.
- The controls are shaped so you recognize them by touch.
- You intuitively know which direction to move them in.

2 **Tapered back support**

More space for your elbows means greater freedom of movement for steering.

3 **Adjustable backrest**

Can be accurately fine-tuned for a relaxed posture.

4 **Pneumatic lumbar support**

A comfort feature that actively prevents spinal injuries by providing maximum support to the area of the back that takes the greatest strain.

5 **Infinite side support adjustment**

Noticeably relieves the pressure on your spine by optimally supporting your back on bends and corners. A vital prerequisite for proper posture, together with the pneumatic lumbar support.

6 **100 mm infinite height adjustment**

The ideal seat height, whatever your height and size.



13 Integrated headrest

Can be easily adjusted to provide ideal support for every driver height.

12 Three-point seatbelt system

Integrated into the seat back and pleasant and comfortable to use. Provides optimum safety without restricting freedom of movement.

LINEA & TOUREA



11 Variable seat depth

Provides ergonomically correct thigh support.

10 Seat angle

Adjustable between -6° and 10°.

9 Turntable (optional) The large pivoting range of 50° to the right and 90° to the left provides maximum freedom of movement and makes it easier to operate the till.

or

Quick Down Pneumatic quick-down feature facilitates getting in and out.

8 200 mm fore/aft adjustment

Lets you customize the distance to the steering wheel and pedals.

7 Adjustable shock absorbers

Optimum suspension comfort to suit any road surface, whether you're on the highway or a bumpy side road.





LOOKING OUT FOR SAFETY.

FEATURES	LINEA		TOUREA	
Art. no. with cover fabric	1055649	1077443	1055627	1077442
Art. no. without fabric cover	1080355	1080356	1049974	1080372
Right-hand controls	●	●	●	●
Adjustable shock absorbers	●	●	●	●
Three-point seatbelt system	●	●	●	●
Suspension travel 80 mm	●	●	●	●
Infinite height adjustment 100 mm	●	●	●	●
Integrated headrest	●	●	●	●
Fore/aft adjustment 200 mm	●	●	●	●
Pneumatic lumbar support	●	●	●	●
Adjustable backrest	●	●	●	●
Infinite pneumatic side support adjustment	●	●	●	●
Adjustable seat depth	●	●	●	●
Adjustable seatback angle	●	●	●	●
Quick Down	●		●	
Turntable 50° right / 90° left		●		●
OPTIONAL FEATURES				
Armrests left/right	○			○
Lap belt	○			
24V seat heating	○			○
Mount* for swiveling seat, height 82 mm			1050968	
Mount* for non-swiveling seat, height 144 mm			1049682	
Mount** for swiveling seat, height 110 mm			1050969	
Mount** for non-swiveling seat, height 172 mm			1078639	

● Standard ○ Optional
 *New driver workplace **Old driver workplace

Important note:

These driver seats may only be used in class M3 vehicles (more than 8 occupants and more than 5 metric tons)!

The model Tourea is only qualified for vehicles which were original equipped with a driver seat with integrated Three-point seatbelt system or specified therefor.

All measurements given in mm. We reserve the right to make technical and dimensional changes.

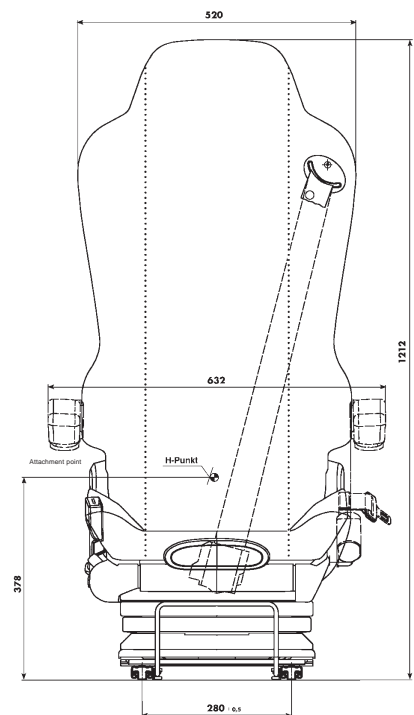

Front view

LINEA and TOUREA
 dimensions are identical.

Seating that's good for you.
Grammer sells ultramodern
seating systems for all moving
workplaces — including buses,
vans, trucks, tractors, construction
machines and forklifts.
Ergonomically designed, they
set new standards in sitting and
operating comfort. Just ask —
we'll be only too glad to help.

